

KOBELCO

SK140SRD
SK210D

Dismantling Machine



We Save You Fuel
Achieving a Low-Carbon Society

Precision dismantling increases the value of end-of-life vehicle resources

Kobelco multi-dismantling machines and car-dismantling machines will help achieve a higher future car recycling rate

Since the establishment of the ELV directive in 2000, Europe has steadily increased the recycling and reuse of used cars and car parts. Various countries have established and refined laws and regulations towards the goal of achieving a substantial reuse/recycling rate of 85%. This and improvements in efficiency of operations at dismantling sites are factors in developing metal recycling industries that do not allow the potential value of used cars go to waste.

At the same time, new cars developed during this time have evolved dramatically through more advanced control, information, and material technologies. Hybrid vehicles continue to become more and more mainstream, and fully electric vehicles have emerged in the market as well. These advancements and changes in the automobile industry will require more precise car dismantling operations in the next 5 to 10 years. Kobelco metal dismantling machines are the solution to achieving such precision. Our machines increase dismantling efficiency so that more units can be processed in the same time. Our machines also enable more precise and complex separating operations so that even the smallest amounts of rare metals and other valuable materials can be collected instead of being lost. We propose this business strategy because we understand the value of end-of-life vehicles as resources and have been promoting full use of these resources for many years now.

Multi-dismantling machine

SK140SRD



JAPANESE QUALITY



Car-dismantling machine

Multi-dismantling machine

SK210D

Machine that Embody 40 Years of Our Experience in Dismantling Sites

Machine designed and built specifically for car dismantling

Piping for the rotating nibbler
Heavy duty open/close and rotation piping for optimum nibbler tool performance.

Reinforced Boom and Arm
Severe duty components are specifically designed and installed at the factory for the most severe dismantling applications.

Front attachments
Kobelco's nibbler tool provides maximum pinching, crushing and cutting power to allow the operator to easily and efficiently remove parts and sort valuable materials.

Heavy duty Cylinders (with load holding valves)
Both the bucket cylinder and arm cylinder are reinforced to withstand high loads. Boom and arm cylinders have holding valves for additional safety.

Cab for the Metal-dismantling machine
Specialized cab with front and top window guarding and safety glass for operator protection.

Boom cylinder guard
Protects the cylinder rods.

Clamp arm
The clamp arm moves vertically (up and down) and closes horizontally (side to side) to hold car better than top only style arms.

Counterweight
Special heavy counterweight is used for increased stability.

Clamp arms

Clamp arms specially designed by Kobelco

The Kobelco designed clamp arms are made to hold a vehicle in multiple positions to provide maximum access for complete dismantling. The clamp arms include additional tools to make dismantling process quicker and more efficient.

Center cover

Made to protect and shed material off the clamp arms.



Multi-dismantling machine (4 way)



Car-dismantling machine (2 way)



Teeth

Used to separate aluminum heads and transmissions from engine blocks.



Puller

Used to remove instrument clusters and circuit boards and to clean wire and harnesses.



Grips

The bowl grips are used to hold the car for dismantling then used to hold smaller items like the engine and dash for additional parts removal.



Anchor

Designed to bend long objects easily.

Overall flow of the car recycling process and the benefits of using multi-dismantling machines

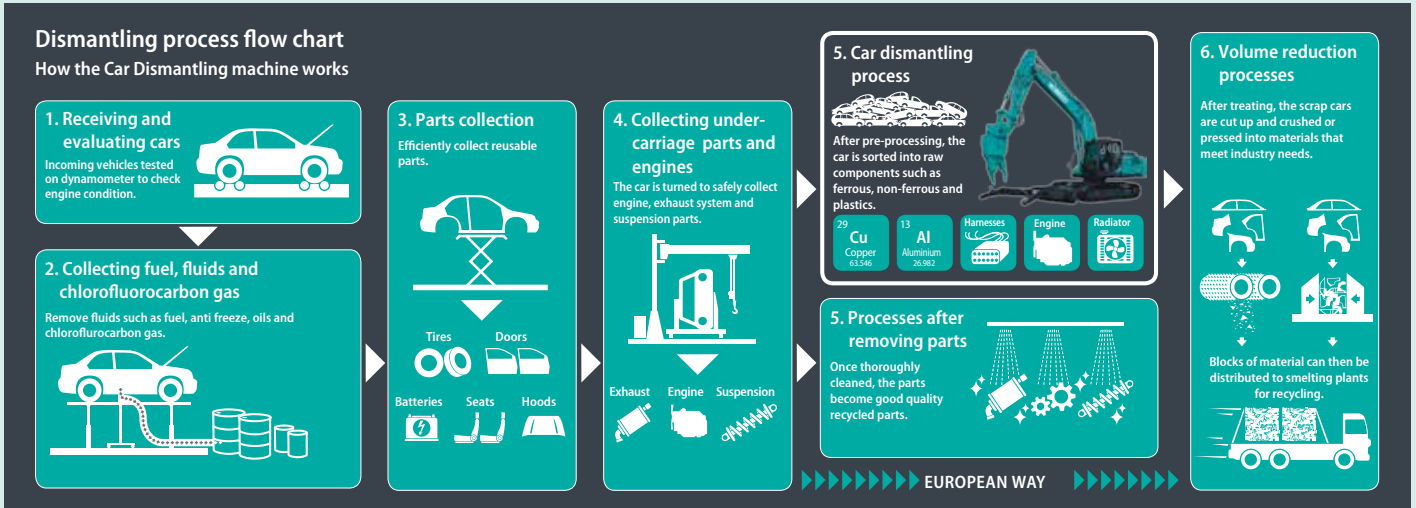

The Evolution of the European car dismantling industry by Kobelco

Four times* the vehicle dismantling capability compared with hand dismantling.
*In one day (Kobelco test figures)

15 vehicles > One operative working by hand.

60 vehicles > One operative in a Kobelco Car Dismantling machine.

The machine's special attachment is designed to strip materials from End-of-Life Vehicles (ELV) safely and thoroughly

Improved recovery rate of rare earth metals

26 Fe Iron 55.933	13 Al Aluminium 26.982	29 Cu Copper 63.546	78 Pt Platinum 195.08	46 Pd Palladium 106.42
-------------------	------------------------	---------------------	-----------------------	------------------------

Separation of these valuable materials is quicker and easier and can be performed with one Kobelco machine.

Front Attachments [nibbler]

Specialized nibbler for more detailed separating processes

The Kobelco nibblers are designed to provide maximum gripping, holding, twisting, breaking and pulling power. Their heavy duty design is made to hold up to severe duty dismantling, yet they are nimble enough to perform delicate and precise operations. The tool for the SK210D has 2 rotation motors to provide additional rotation force for increased productivity to the customer.



Multi-dismantling nibbler KHE750PR-2 Multi-dismantling nibbler KVE720PR Car-dismantling nibbler KV800PR

Heavy duty design and construction of the body, tine, pivot group allows for maximum production and ease of maintenance.

Multi-dismantling nibbler

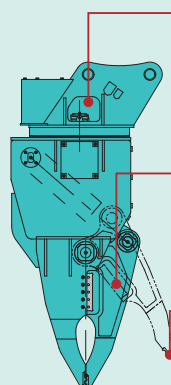

360 degree rotating tool

Powerful rotation torque enables effective twisting and stripping motions via the proportionate control button on the left joystick. Movements are quick, controlled and precise.

Shear/cutter blades

The powerful shear/cutter blades at the back of the jar allow the operator to cut vehicle frames and chassis or downsize other materials.

Powerful crushing force

The interlocking replaceable teeth are made to grip and hold material securely, yet nimble enough to grab and pick up a single wire.

Smooth and Efficient Work Process Realized by Our Advanced Technologies and Thorough Care

Cab interference prevention system

The cab interference prevention system is provided as standard equipment to prevent the nibbler from contacting the cab during operation. Precise detection of the position and orientation of the nibbler minimizes the interference warning range to enable a larger effective working area. Since the nibbler tool is restricted from coming into contact with the cab, the operator is able to work more productively and with more focus on the dismantling process.

System operation

Audible and visual warnings appear when nibbler tool approaches the cab, but the machine stops it before it any contact to the cab is made.



How it works

The system calculates the boom angle, arm angle, idler link motion angle to come up with the position and direction of the front attachment to control its motion.



Boom angle sensor



Arm angle sensor



Bucket angle sensor

Comfortable operating environment

The large roomy cab has a wide open view thru the large front and side windows. Posts are small and minimized to further reduce blind spots and distractions. The cab is also air tight, with inside and outside A/C filters and rides, rides on suspension springs. All to keep operator comfortable and productive.



Suspension seat absorbs vibration



Reclining seat has a wide recline angle

Nibbler rotation left
Nibbler rotation right



Nibbler Open
Nibbler Close



Clamp arm Open
Clamp arm Close



Clamp arm Down
Clamp arm Up

Intuitive operation

Machine operation feels natural and is simplified by making the clamp arms operate by foot pedals and the nibbler by the joystick mounted rocker switches. Levers, pedals and switches are easily operable without requiring excessive force to prevent fatigue during extended periods of use.

Environmentally Friendly Engine

NOx emissions cut

New TIER IV Final compliance engine

The SK140SRD is fitted with Diesel Oxidation Catalyst (DOC) and Selective Catalytic Reduction (SCR) for emission control. The larger SK210D utilizes SCR and a Diesel Particulate Filter (DPF) for emission control. Both machines have large capacity DEF/AdBlue* tanks to extend fill intervals.

*AdBlue® is a registered trade mark of the Verband der Automobilindustrie e. V. (VDA).

■ NOx reduction rate
(Compared to previous models)

About **88%** decrease

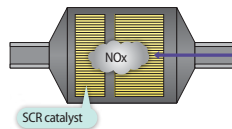

At high temperatures, nitrogen and oxygen combine to produce nitrous oxides (NOx). Reducing the amount of oxygen and lowering the combustion temperature results in much less NOx.

EGR cooler

While ensuring sufficient oxygen for combustion, cooled emission gases are mixed with the intake air and recirculated into the engine. This reduces oxygen content and lowers combustion temperature.

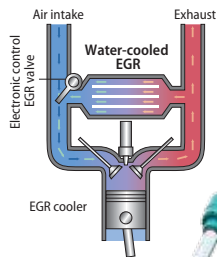

PM emissions cut

Particulate matter (PM) is mostly soot resulting from incomplete combustion; Improved combustion efficiency reduces PM emissions.

Common rail system

High-pressure injection atomizes the fuel, and more precise injection improves combustion efficiency. This also contributes to better fuel economy.

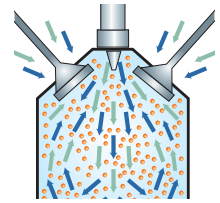

Common rail system



SK210D

Unique engine cooling system -iNDR- <Only on SK140SRD>

iNDR absorbs sound energy to minimize noise by making a path of air, which cools down the engine. The SK140SRD is equipped with a selective catalytic reduction (SCR) unit, which required a new design with two offset ducts on top. This allows ample space to absorb engine noise.



Eliminating dust maintains cooling system performance

The high-density 30-mesh* filters dust in the intake air. This prevents clogging of the cooling system and the air cleaner, which maintains peak performance. The waveform filter allows air through the tops of the waves while collecting dust at the bottom, ensuring a smooth airflow.

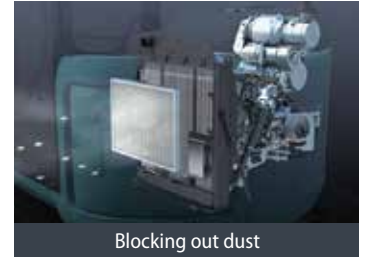

Blocking out dust

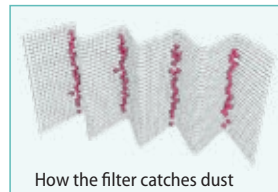

How the filter catches dust

30-mesh means that there are 30 holes formed by horizontal and vertical wires in every square inch of filter.

Safety equipment for protecting workers and allowing them to be free of stress and anxiety.



Front guard (Vertical guard)

Front windows are protected by a vertical guard to prevent damage and provide additional safety for the operator.



Top guard level II (Meets ISO10262)

The standard grid type cab ceiling guard protects the operator against objects falling on the cab roof.



Front window

Front and right side window have tear and penetration-resistance film to hold glass fragments together.



Rear-view camera

Standard machine safety feature to protect the operator, personnel around the machine, and surrounding equipment.



Cab entry step

The larger step makes it easy for the operator to climb into and out of the cab.



Lower frame step (SK210D only)

An additional step is installed on the side of the crawler frame.



One way call

Operator is able to alert ground workers without taking their hands off the machine controls.



Fuel fill-up pump (SK210D only)

Quick, safe fuel fill-ups possible from a standing position without the need to mount upper carriage.



Cab with two LED lights

Highly bright long-life LED lights are equipped as standard working lights.



Boom with two lights

Working lights are equipped as standard on both sides of the boom.



Heavy weight

The additional weight ensures substantial stability, making it easier to grab and raise heavy objects such as end-of-life vehicles.



SK140SRD

Color Multi-display

Color Multi-display

Brilliant colors differentiate multiple graphics on cab LCD. Graphics indicate fuel consumption, maintenance intervals and more.



- 1 Analog-style gauges provide an intuitive reading of fuel level and engine temperature
- 2 Green indicates ECO-mode selected or efficient operation in other modes
- 3 PM accumulation (left-SK210D only) / DEF level (right)
- 4 Fuel consumption/Rear-view camera
- 5 Digging mode switch
- 6 Monitor display switch



Cab interference prevention alarm



Fuel consumption

Item	Interval	Current
ENGINE OIL	500	495
FUEL FILTER	500	495
HYD. FILTER	1000	995
HYD. OIL	5000	4995

Maintenance

Energy-efficient System

ECO-mode: engineered for economy

Kobelco's ECO-mode maximizes the operating efficiency of the engine and other components to achieve much greater fuel efficiency. Just press a button to choose the operation mode best suited to the task at hand and the working conditions.

Optimal operation with three modes

- H** H-mode • • • Maximum power for maximum productivity on your toughest jobs
- S** S-mode • • • Ideal balance of productivity and fuel efficiency for a range of urban engineering projects
- E** ECO-mode • • • Minimum fuel consumption for utility projects and other work that demands precision

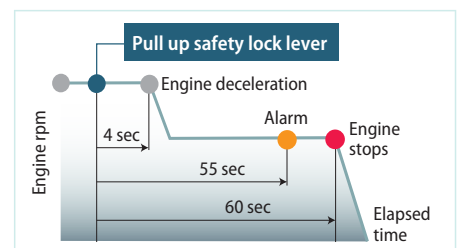

AIS (Auto Idle Stop)

If the boarding/dismarking lever is left up, the engine will stop at a predetermined time automatically. This eliminates wasteful idling during standby, saving fuel and reducing CO₂ emissions as well.

Our Long-Life Philosophy of Maintaining Long-term Performance

Body frame designed for improved strength

*Green areas represent components of the specialized design.

These machines have reinforced frames and specially designed swing areas due to the heavier counterweight and clamp arms. These reinforcements are made when the machine is manufactured to ensure durability and longevity. Since Kobelco has been building and refining the dismantler machines for over 40 years, they know what stresses the machine can go through. By addressing these areas from the start, it avoids the breakdowns and repairs that are seen on competitive lighter duty units.



Frame is reinforced from the factory to support the heavier counterweight.

Upper frame



SK140SRD

Lower frame



SK140SRD

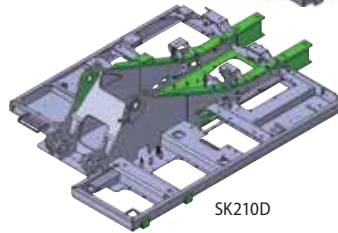

SK210D

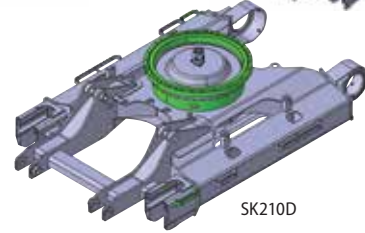

SK210D

Factory designed and installed rugged and durable attachments

*Green areas represent components of the specialized design.

Thick steel plates have been added to the HD arm right, left, and front sides of the boom to resist twisting. The sides and back of arms are reinforced with thick plates, and there is a rock guard added the end of the arm to further reinforce and protect it from damage.



High-strength multi-dismantling attachment

HD arm



SK140SRD

HD boom



SK140SRD



SK210D

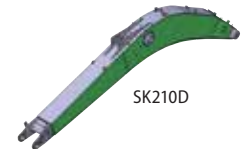

SK210D

The factory, purpose built structures, maximize durability, while reducing maintenance costs.



Boom cylinder guards

Guided reinforced boom cylinder guard with box-type structure



Dismantling arm cylinder

Heavy duty arm cylinder made specifically for dismantling application.



Dismantling bucket cylinder

Use of a dedicated cylinder with heavy duty components.



Boom & arm holding valves

Standard - to prevent boom or arm from falling if hose is damaged.



Upper frame under cover guards

Upper frame belly guards. Reinforced guarding to protect the engine, hydraulic system and operator station.



Swivel guard

Heavy duty guarding for hydraulic components in the swivel / swing area.



Dust-proof fuel tank cap

The fuel cap is lined with rubber to prevent dust from contaminating the fuel tank.



Work boot tray

The operator is able to put dirty work boots in outside tray to keep cab cleaner.



SK210D

KOMEXS KOBELCO MONITORING EXCAVATOR SYSTEM

Total Support for Machines with Network Speed and Accuracy

KOMEXS is a satellite-based system for receiving machine information. Manage your machines anywhere in the world using the Internet. Location, workload and diagnostic data aid business operations.

Direct Access to Operational Status

Location Data

Accurate location data can be obtained even from sites where communications are difficult.

Operating Hours

A comparison of operating times of machines at multiple locations shows which locations are busier and more profitable.

Operating hours on site can be accurately recorded, for running time calculations needed for rental machines, etc.

Fuel Consumption Data

Data on fuel consumption and idling times can be used to indicate improvements in fuel consumption.

Graph of Work Content

The graph shows how working hours are divided among different operating categories, including digging, idling, traveling, and optional operations (N&B).



Maintenance Data and Warning Alerts

Machine Maintenance Data

Provides maintenance status of separate machines operating at multiple sites. Maintenance data is also relayed to KOBELCO service personnel, for more efficient planning of periodic servicing.

Security System

Engine Start Alarm

Sends a notification if the engine is started outside of pre-defined hours.

Area Alarm

Sends a notification if the machine leaves a pre-defined area.



iNDR filter

The cooling system includes an iNDR dust filter to make daily cleaning system cleaning an easy process. (SK140SRD only)



Removable screens for easy cleaning

Easily removable screens to prevent material from clogging the cooling system. (SK210D only)



Hydraulic oil filter

Glass filtration material with outstanding cleaning ability and durability is used.



Maintenance space

The upper space provides a comfortable platform for maintenance inside the engine hood.

SK140SRD

Multi-dismantling machine



Engine

Model	ISUZU AR-4JJ1XASK-02
Type	4 cycle, water cooled, overhead valve, vertical in-line, direct injection type, with turbo-charger. Tier IV certified.
No. of cylinders	4
Bore and stroke	95.4 mm x 104.9 mm
Displacement	2.999 L
Rated power output	71.3 kW / 2,000 min ⁻¹ (ISO 9249 : with fan)
	78.5 kW / 2,000 min ⁻¹ (ISO 14396 : without fan)
Max. torque	347 N-m / 1,800 min ⁻¹ (ISO 9249 : with fan)
	375 N-m / 1,800 min ⁻¹ (ISO 14396 : without fan)



Hydraulic System

Pump	
Type	Two variable displacement piston pumps
Max. discharge flow	2 x 130 L/min
	1 x 20 L/min
Relief valve setting	
Excavating circuits (main)	34.3 M Pa
Travel circuit	34.3 M Pa
Swing circuit	28.0 M Pa
Pilot control circuit	5.0 MPa
Nibbler (Crusher) circuit	Open & Close 24.5 MPa Rotation 20.6 MPa
Clamp arm circuit	Open & Close 24.5 MPa Up & Down 24.5 MPa
Main control valve	8-spool
Oil cooler	Air cooled type



Swing System

Swing motor	Axial piston motor
Parking brake	Oil disk brake, hydraulic operated automatically
Swing speed	11.0 min ⁻¹
Swing torque	39.9 kN-m (SAE)
Tail swing radius	1,600 mm
Min. front swing radius	2,140 mm



Travel System

Travel motors	2 x axial piston, two-speed motors
Travel brakes	Hydraulic brake per motor
Parking brakes	Oil disk brake per motor
Travel shoes	44 pads (each side)
Travel speed	5.6 / 3.4 km/h
Drawbar pulling force	138 kN (SAE J 1309)
Gradeability	70% {35°}



Refilling Capacities & Lubrications

Fuel tank	190 L
Cooling system	9.0 L
Engine oil	13.0 L
Travel reduction gear	2 x 2.1 L
Swing reduction gear	1.65 L
Hydraulic oil tank	79.3 L tank oil level
	168.0 L hydraulic system
DEF/AdBlue tank	33.9 L



Clamp arm ability

Crushing force (clamp arm tooth for rear)	324 kN
Crushing force (clamp arm tooth for front)	216 kN
Clamping force (clamp arm grip)	137 kN

Operating Weight & Ground Pressure

Shoe width	500 mm
Ground pressure	63 kPa
Operating weight	20,100 kg

SK210D

Multi-dismantling machine / Car-dismantling machine



Engine

Model	HINO J05EUM-KSSC
Type	Direct injection, water-cooled, 4-cycle diesel engine with turbocharger, intercooler. (Complies with EU (NRMM) Stage IV, EPA Tier IV Final)
No. of cylinders	4
Bore and stroke	112 mm x 130 mm
Displacement	5.123 L
Rated power output	119 kW / 2,000 min ⁻¹ (ISO 9249 : with fan)
	124 kW / 2,000 min ⁻¹ (ISO 14396 : without fan)
Max. torque	640 N-m / 1,600 min ⁻¹ (ISO 9249 : with fan)
	660 N-m / 1,600 min ⁻¹ (ISO 14396 : without fan)



Hydraulic System

Pump	
Type	Two variable displacement pumps + 1 gear pump
Max. discharge flow	2 x 220 L/min
	1 x 20 L/min
Relief valve setting	
Excavating circuits (main)	34.3 MPa
Travel circuit	34.3 MPa
Swing circuit	29.0 MPa
Pilot control circuit	5.0 MPa
Nibbler (Crusher) circuit	Open & Close 24.5 MPa Rotation 20.6 MPa
Clamp arm circuit	Open & Close 24.5 MPa (Multi-dismantling machine only) Up&Down 24.5 MPa
Main control valve	8-spool
Oil cooler	Air cooled type



Swing System

Swing motor	Axial piston motor
Parking brake	Oil disk brake, hydraulic operated automatically
Swing speed	12.7 min ⁻¹
Swing torque	71.5 kN-m (SAE)
Tail swing radius	2,910 mm
Min. front swing radius	3,540 mm



Travel System

Travel motors	2 x axial piston, two-speed motors
Parking brakes	Oil disk brake per motor
Travel shoes	46 pads (each side)
Travel speed	6.0 / 3.6 km/h
Drawbar pulling force	229 kN (SAE J 1309)
Gradeability	70 % {35°}



Refilling Capacities & Lubrications

Fuel tank	320 L
Cooling system	19 L
Engine oil	20.5 L
Travel reduction gear	2 x 5.3 L
Swing reduction gear	2.7 L
Hydraulic oil tank	140 L tank oil level
	244 L hydraulic system
DEF/AdBlue tank	83 L



Clamp arm ability

Crushing force (clamp arm tooth)	333 kN (Multi-dismantling machine)
Clamping force (clamp arm grip)	177 kN (Multi-dismantling machine)
Pressing force (clamp arm tip)	83 kN (Car-dismantling machine)

Operating Weight & Ground Pressure

Shoe width	600 mm
Ground pressure	67 kPa (Multi-dismantling machine)
	62 kPa (Car-dismantling machine)
Operating weight	30,000 kg (Multi-dismantling machine)
	27,400 kg (Car-dismantling machine)



Dimensions

SK140SRD

Multi-dismantling machine

Unit : mm

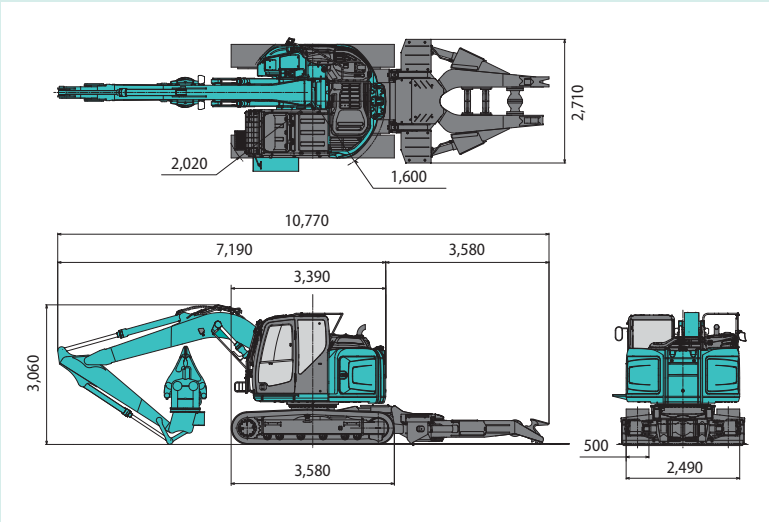

Working Ranges

Multi-dismantling machine

Unit : mm

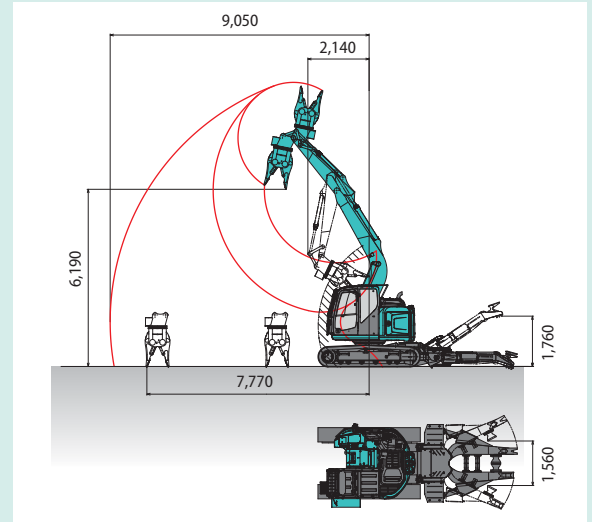

SK210D

Multi-dismantling machine

Unit : mm

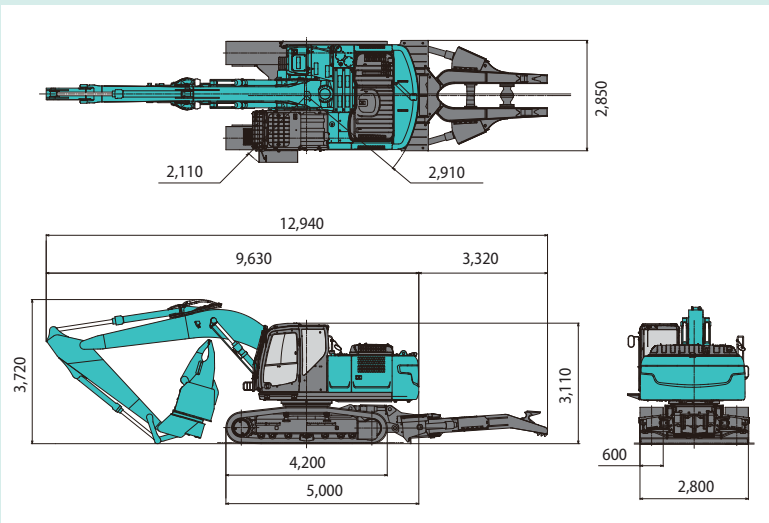

Multi-dismantling machine

Unit : mm

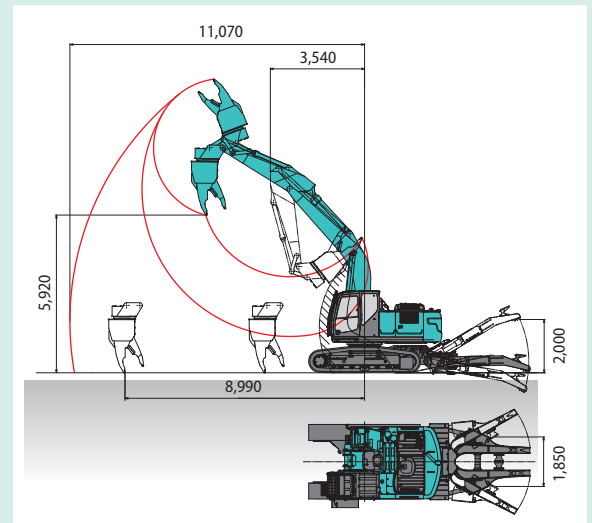

Car-dismantling machine

Unit : mm

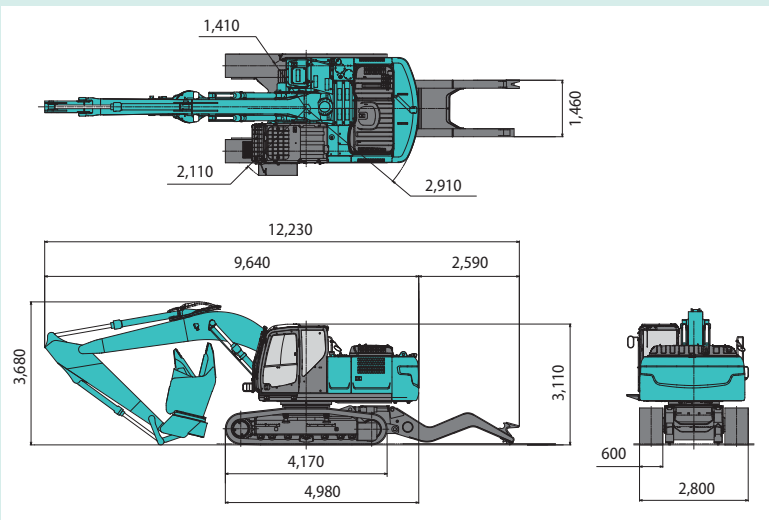

Car-dismantling machine

Unit : mm

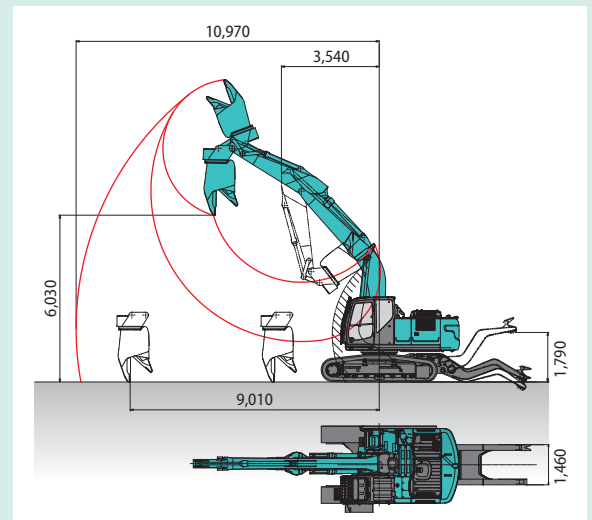



Front Attachments

Model		KHE750PR-2	KVE720PR	KV800PR
Machine		SK140SRD	SK210D	SK210D
Weight		940 kg	1,850 kg	2,100 kg
Shearing force (blade center)		255 kN	539 kN	882 kN
Crushing force (tooth-jaw tip)		88.3 kN	196 kN	372 kN
Operating pressure	open / close	24.5 MPa	29.4 MPa	29.4 MPa
	rotation	17.7 MPa	14.7 MPa	14.7 MPa

Nibbler

Unit : mm

Unit : mm

Unit : mm

Multi-dismantling nibbler KHE750PR-2

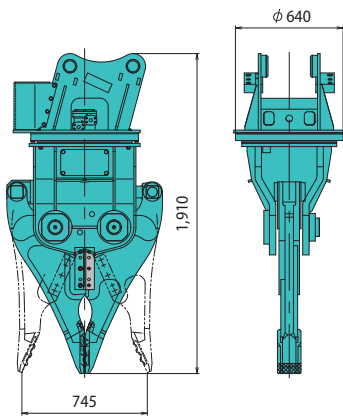

Multi-dismantling nibbler KVE720PR

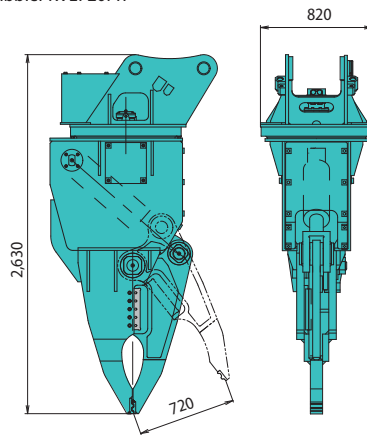

Car-dismantling nibbler KV800PR

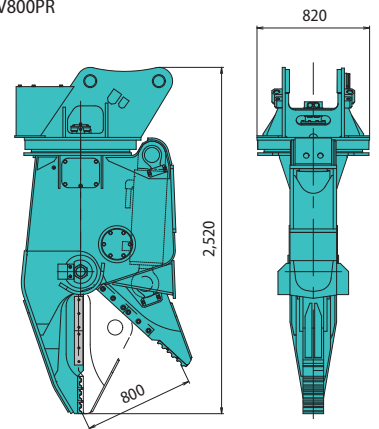

STANDARD EQUIPMENT

ENGINE

SK140SRD

- ISUZU AR-4JJ1XASK-02 Tier IV diesel engine with turbocharger and intercooler
- Two 12 volt 80Ah batteries
- 24V-5kW starter
- 50-amp alternator

SK210D

- HINO J05EUM-KSSC Tier IV diesel engine with turbocharger and intercooler
- Two 12 Volt 96Ah batteries
- 24V-5kW starter
- 60-amp alternator

Common Features

- Automatic engine deceleration
- Proportionate engine accelerate
- Removable clean out screen
- Double element air cleaner
- Automatic low engine oil pressure shut down
- Side by side oil, hydraulic and engine radiators

HYDRAULIC

- Hydraulic oil cooler
- Hydraulic oil filter condition indicator

SWING SYSTEM & TRAVEL SYSTEM

- Swing rebound prevention system
- Two-speed travel with automatic shift down
- Sealed & lubricated track links
- Grease-type track adjusters
- Automatic swing brake

MIRRORS, LIGHTS & CAMERA

- Two rearview mirrors
- Rear-view camera
- Right side camera, additional monitor
- Three front working lights (1 on upper carriage, 2 on cab)
- Two attachment front working lights

CAB & CONTROL

- Two control levers, pilot-operated
- Cab light (interior)
- Coat hook (only SK140SRD)
- Large cup holder
- Detachable two-piece floor mat
- Air suspension seat with armrests
- Retractable seatbelt (only SK140SRD)
- Cab entry and engine access handrails
- Heater and defroster
- Intermittent windshield wiper with double-spray washer

- Sky light
- Front guard (grid type 2-face guard)
- Top guard level II (Meets ISO10262)
- Tinted safety glass and shatterproof film
- Pull-type front window and removable lower front window
- Easy-to-read multi-display monitor
- Automatic air conditioner
- Emergency escape hammer
- Radio, AM/FM Stereo with speakers
- 12V power source
- AUX, USB, Bluetooth
- Cab entry step

- Boom & arm holding valve
- Cab interference prevention system
- 9 mm thick swivel guard
- 6 mm thick upper frame under coverguards
- Reinforced travel motor covers
- Rotation and N&B auxiliary circuits and piping
- Boom cylinder guards
- Work boot tray
- One way call
- KOMEXS
- Heavier counter weight (+1,670kg) (only SK210D)
- Additional counter weight (+580kg) (only SK140SRD)

OPTIONAL EQUIPMENT

- Front screen (mesh type 2-face guard)
- Flat shoes
- Travel alarm
- Cab front polycarbonate guard
- Extended guard rail (only SK210D)



Note: This catalog may contain attachments and optional equipment that are not available in your area. And it may contain photographs of machines with specifications that differ from those of machines sold in your areas. Please consult your nearest KOBELCO distributor for those items you require. Specialist equipment is needed to use this machine in demolition work. Before using it please contact your KOBELCO dealer. Due to our policy of continuous product improvements all designs and specifications are subject to change without advance notice.
Copyright by **KOBELCO CONSTRUCTION MACHINERY CO., LTD.** No part of this catalog may be reproduced in any manner without notice.

KOBELCO CONSTRUCTION MACHINERY EUROPE B.V.

Veluwezoom 15
1327 AE Almere
The Netherlands
www.kobelco-europe.com

Inquiries To: