

## *STARK RSW -BOTARY SWEEPERS, S-MODELS*

- Powerful, versatile and agile brush device for year-round use
- The hydraulic motor is integrated inside the brush roller for protection against impacts



- 900 mm lamellas, vertical (250 mm) and horizontal float (12 °) guarantee a finished brushing mark even on uneven work sites.
- The large 30 ° turning angle allows brushing right next to walls, railings, etc. 900 mm lamellas are the most cost-effective option.
- A separate turning frame keeps the brush roller straight at all turning angles.
- The coupling with a buffer protects the hydraulic motor of the brush roller in the event of start-up and collisions.
- The spring and gas shock absorbers hold the brush roller firmly to the surface to be brushed.
- The bolt-on STARK FIT adapters can be quickly replaced according to the quick coupler of the basic machine.
- Accessories: High-pressure dust binding system with hydraulic Dynaset water pump, directional high-pressure nozzle hose, low-pressure watering system with 12 or 24V water pump, directional low-pressure nozzle hose, 2- or 4-hose hydraulics, reverse valve 12 or 24V for brush roller.



*STARK attachments have been manufactured for over 40 years*



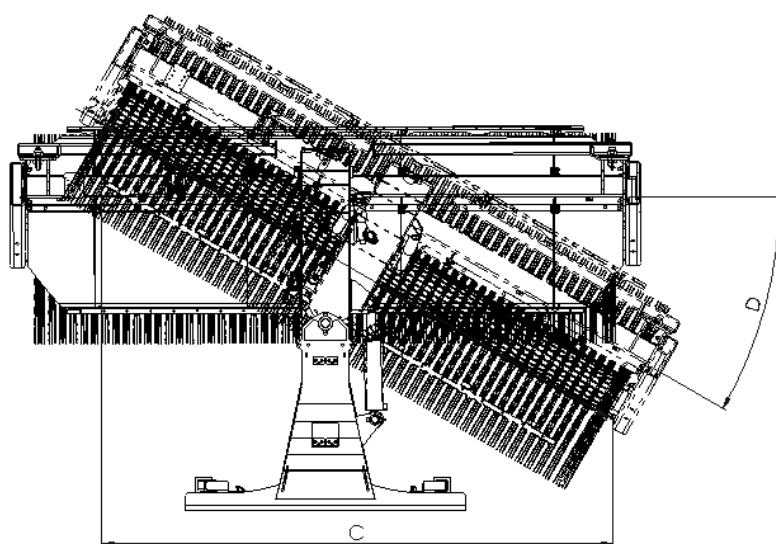
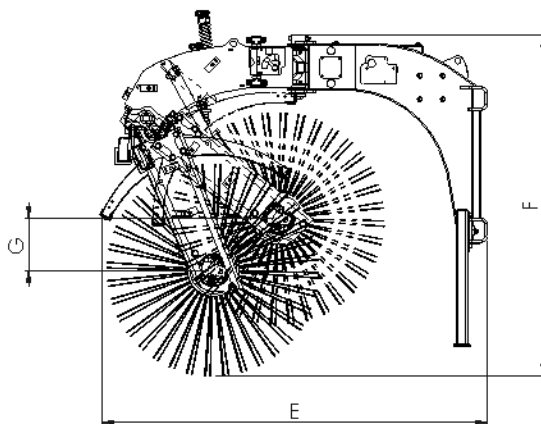
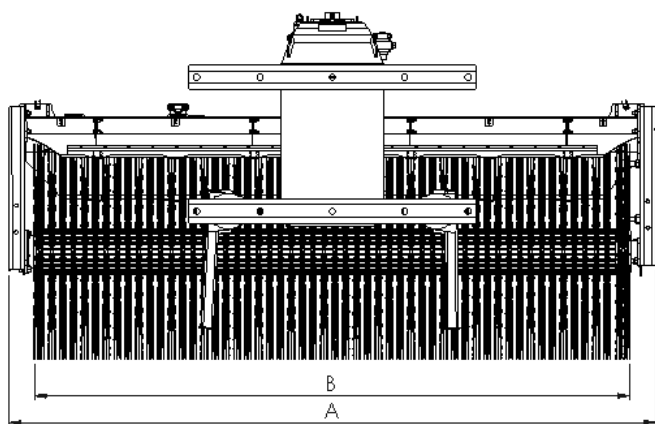

Product	Max. width (mm)	Working width (mm)	Brushing width with turning angle (mm)	Turning angle $\pm$ ( $^{\circ}$ )	Length (mm)	Height (mm)	Max. Floating (mm)	Min. oil absorption (l/min)	Max. oil flow (l/min)	Return line max. counterpressure (bar)	Weight (kg)
	A	B	C	D	E	F	G				
RSW 2500 S	2700	2500	2200	30	1650	1450	250	55	120	120	580
RSW 3000 S	3200	3000	2700	30	1650	1450	250	55	120	120	620

\* Note! Weight may vary depending on fitting type/brush accessories

\*\* Available with a flow limiter, if the output is more than 120 l/min