

STARK –BUCKET SWEEPERS, ASF -MODELS

- Specially designed for heavy and abrasive asphalt work
- The robust bucket sweeper is a reliable and long-lasting special work tool



- The robust **HARDOX 400 bucket** withstands wear and shocks.
- Bucket lip plate made of 500 HB wear steel, boltable 16 mm Saving blades and edge wear pieces (not shown) protect the bucket from wear.
- **SUNLINE 900 mm** lamellas improve the work surface on uneven brushing areas. The large hopper volume reduces emptying intervals.
- The hydraulic motor is integrated inside the brush roller for protection against impacts. The coupling with a buffer protects the hydraulic motor of the brush roller in starting and collision situations.
- The large opening angle of the brush roller allows a full unloading angle directly on the platform. When the brush roller rises, the bucket can also be turned straight down when tipping onto the platform.
- Optional equipment: COMBI Hydraulics (brush rotation and brush lifting with 2 hoses), 4-hose hydraulics (separate brush rotation and brush body lifting), programmable hydraulics (5 functions) + control unit for cab, numerous welded adapters options, various hydraulic quick couplers.
- Accessories: support rollers, **PIN FLOAT** vertical and horizontal float with welded adapters OR **Hydraulic side shift** 600 mm with VOLVO BM welded adapters (requires one hydraulic block or solenoid valve 12 or 24V), side brushes with hydraulic lift (requires one hydraulic block or solenoid valve 12 or 24V).



STARK –attachments have been manufactured for over 40 years

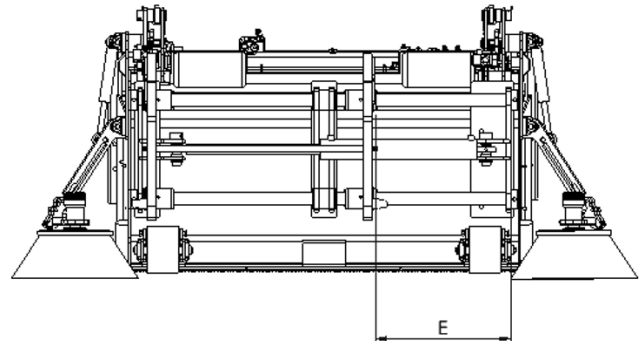
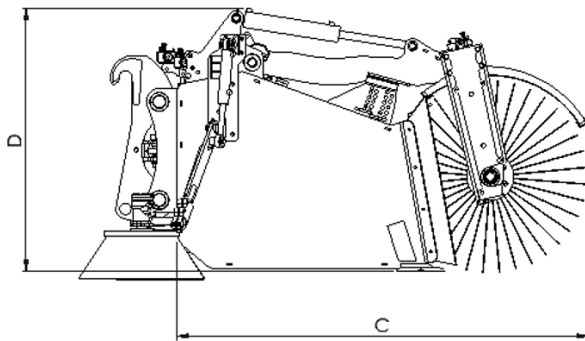
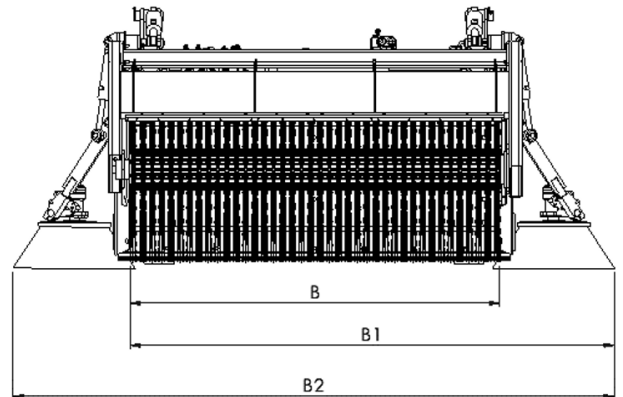
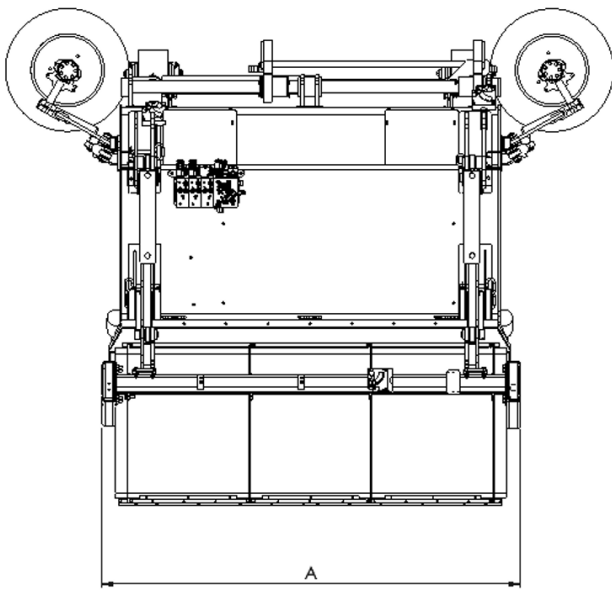

Product	Max. width (mm)	Working width (mm)	Max working width 1x side brush (mm)	Max working width 2x side brush (mm)	Length (mm)	Height (mm)	Hydraulic side shift (mm)	Main broom diameter (mm)	Trash container capacity (l)	Min. oil absorption (l/min)	Max. oil flow (l/min)*	Max. pressure (bar)	Return line max. counterpressure (bar)	Operating weight (kg)**	Max operating weight (kg)***
	A	B	B1	B2	C	D	E								
BSW 1800 ASF	2000	1800	2350	2900	1900	1200	600	900	1750	55	120	200	100	1200	1450
BSW 2000 ASF	2200	2000	2550	3100	1900	1200	600	900	1950	55	120	200	100	1300	1550

*Available with flow limitation valve if oil output exceeds 120 l/min

** Weight with Volvo BM adapter, without side shift and side brushes. Note! The weight varies depending on the type of adapter

*** Weight incl. Volvo BM adapters, hydr. side shift, 2 x side brushes. Note! The weight varies depending on the type of adapter