

STARK -TOWABLE SPREADER

- Professional's choice
- Powerful, versatile and durable work tool for professional use



- Strong structure and high quality components ensure trouble-free miles of spreading
- Dual pressure relief valve, flow control valve, crushing axel, safety net, rear lights, fenders, a slow moving vehicle triangle and tires 400/60-15.5 always supplied as standard

**PRECISE
SPREAD**

- Optional hot-dip galvanizing, which protects the towable spreader's tank from corrosion



STARK –attachments have been manufactured for over 40 years

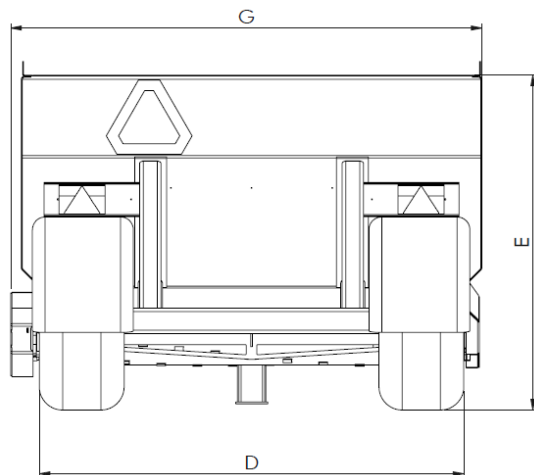
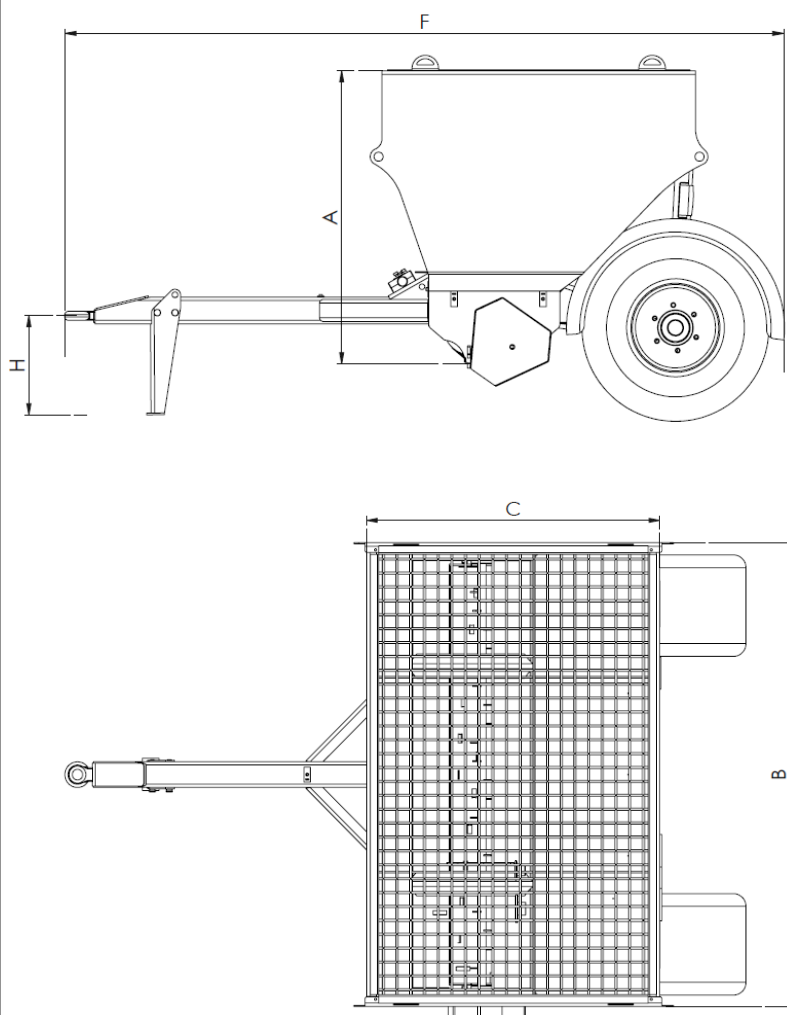

Product	Tank height (mm)	Tank width (mm)	Tank length (mm)	Graveling width (mm)	Total height (mm)	Total length (mm)	Total width (mm)	Drawbar height (mm)	Water tank capacity (m ³)	Capacity of container m ³ (SAE 1:2)	Weight (kg) *
	A	B	C	D	E	F	G	H			
VHK 1800	1230	1870	1400	1670	1580	3200	1910	445	2,20	2,50	900
VHK 2500	1230	2150	1400	1970	1580	3230	2220	445	2,50	3,00	1020

*NOTE! Weight may vary depending on accessories