

STARK -COLLECTING SWEEPER, S-MODEL

- Professional's choice for brushing streets and courtyards
 - Designed to give great performance
 - Good visibility increases occupational safety
-
- Thanks to its rugged design and high quality components, the sweeper is durable, reliable and fail-safe
 - 900 mm lamellas enhance the plowing success and cost-effectiveness
 - Optional high-pressure dust oppression system reduces the volume of road dust and water consumption
 - Hydraulic rising side brushes (optional) fold in front of the main brush. When in the raised position, the side brushes do not take up space from the main brush either laterally or longitudinally
 - Large bottom access panel allows the sweeper to be emptied easily
 - Hydraulic motor is integrated into the brush roller, thus protecting it against impact
 - Flotation of the brush roller and fitting ensure a finished brushing result and protects the brush against damage
 - Stepless brush height adjustment
 - Bolt-on STARK-fit fitting can be changed quickly to match the base machine's fitting
- There is a range of hydraulic options available for STARK brushes, such as hydraulic lifting of the side brush, which stops the side brush from rotating and the dust from binding when the side brush is raised
-
- Accessories: Optional high-pressure dust suppressions system, high-pressure cleaning equipment, low-pressure irrigation system, side brushes with mechanical or hydraulic lift

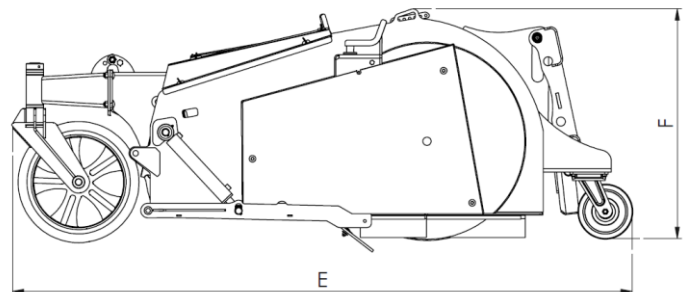

STARK attachments have been manufactured for over 40 years

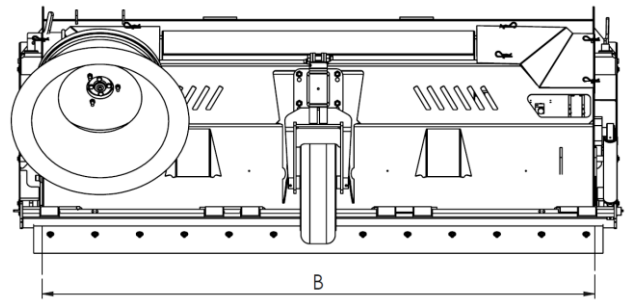
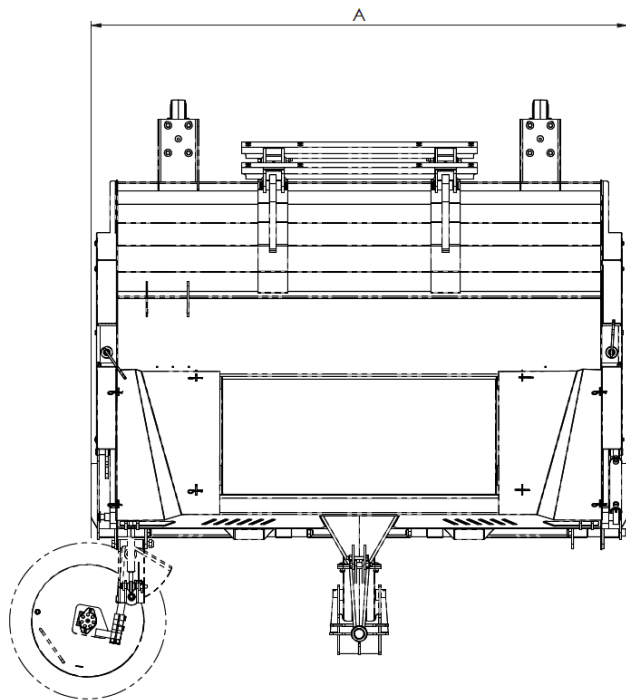

Product	Max. width (mm)	Working width	Main broom diameter (mm)	Length (mm)	Height (mm)	Side brush working width	Water tank (l)	Dust container capacity (l)	Min. oil absorption (l/min)	Max. oil flow (l/min)	Max. pressure (bar)	Return line max. counter pressure (bar)	Weight (kg) **
	A	B		E	F								
KH 1600 S*	1850	1600	900	2460	1070	450	255	560	55	120	200	100	990
KH 2000 S*	2245	2000	900	2500	1070	450	255	700	55	120	200	100	1070
KH 2500 S*	2730	2500	900	2830	1070	450	255	1000	55	120	200	100	1450

*Available with flow limiter if capacity exceeds 120 l/min

**Weight includes fitting, watering system and 1 x side brush. Note! Weight may vary depending on fitting type.